



Model 17800-Series

PORTA QUICK OIL CHANGER

FEATURES

- Pump Body:** Bronze construction
- Impeller:** Nitrile (oil resistant)
- Shaft Seal:** Lip Type
- Motor:** Reversible with integral reversing switch
- Container:** Plastic with 14 quart capacity
- Power Cord:** 8 feet with alligator clips
- Suction Hose:** 4 feet of neoprene hose with 40 inch Teflon* dipstick probe
- Dimensions:** 13-1/2" (343mm) diameter, 13-5/8" (354mm) high
- Weight:** 9 lbs. (4.1 kg)

OPERATING INSTRUCTIONS

1. Run the engine approximately 5 minutes to heat oil (minimum oil temperature 140°F; maximum 185°F), then shut off engine prior to oil removal.
2. Push the 1/2" suction hose onto the pump inlet hose fitting. Position one hose clamp on the end and tighten to secure the hose to the hose barb.
3. If using the 1/4" dipstick probe (instead of the Female Garden Hose Connector), insert the probe into the 1/4" x 1/2" (approximately 1" long) rubber bushing until the end of the probe and the bushing are flush with each other. Slide the hose clamp over the end of the 1/2" hose and position the end of the plastic probe, with bushing attached, in the end of the suction hose. Slide the hose clamp to a position where it will be approximately centered over the probe/ hose bushing, and with a pair of pliers, squeeze it together very tightly to affect a positive airtight seal.

If using the Female Garden Hose Fitting, install it onto the end of the 1/2" suction hose by inserting the

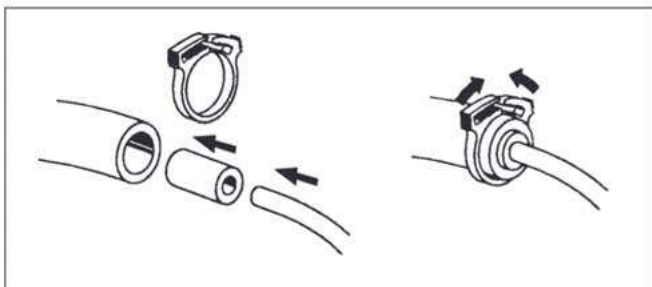

Model 17800-Series

1/2" barb fitting into the hose and secure it by screwing together the two halves of the plastic clamp on the hose at the position of the barb.

4. Clamp the power cord alligator clips (red to positive and black to negative) to the terminals of an appropriate voltage battery.

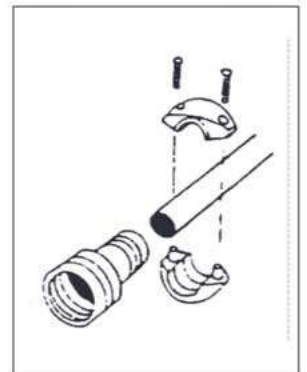

NOTICE: Failure to use proper size fuse in power cord fuse holder may cause motor damage and void warranty.

Model Number	Voltage	Amp Draw	Fuse Size
17800-2000	12	7	10
17800-2090**	12	7	10
17800-2024**	24	3-1/2	5

** Models 17800-2090 and 17800-2024 conform with EN50081-2 for suppression of electro-magnetic interference and are CE marked.

WARNING Explosion hazard. Motor switch must be in "OFF" position when connecting and disconnecting alligator clips to battery terminal and ground. The switch in an "ON" position can cause an electrical spark which can result in explosion. Injury or death can occur.

WARNING Explosion hazard. Take necessary precautions to ventilate area around battery of potentially explosive gases. Continue ventilation during oil changing procedure. Failure to do so can result in explosion. Injury or death can occur.

Four simple steps for fast, clean oil changes

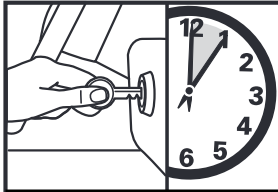

STEP 1

Start engine and run for 5 minutes to heat the oil.

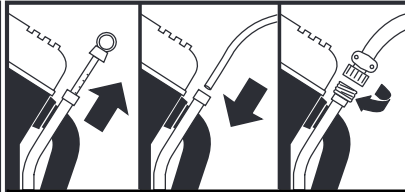

STEP 2

Remove the dipstick and insert the probe tube or attach the garden hose adaptor.

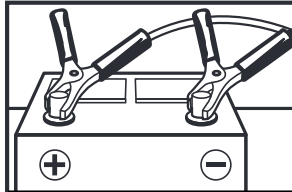

STEP 3

Attach the power cord clips to the engine's battery.
Orange = Positive
Black = Negative

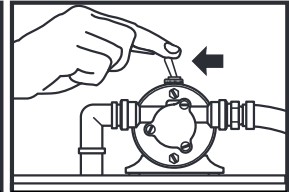

STEP 4

Flip the pump motor switch to drain the crankcase.

- If using the 1/4" dipstick probe, insert it into the dipstick tube until it hits the bottom of the pan. If it is not obvious when the probe hits the bottom of the pan, it may be helpful to measure the distance from the top of the dipstick tube to the bottom of the pan and mark this length on the probe with a piece of tape. Once the probe has hit the bottom of the pan, pull it back up about 1/8" - 1/4" and hold the probe in that position or secure it with some tape during the oil removal process.

NOTICE: Do not push the dipstick probe too far into the engine or it may get caught on internal components and cause a problem when removing.

If using the Female Garden Hose Fitting, simply screw it onto the Male Garden Hose Thread, when provided, on the top of the dipstick tube until it is tight enough to ensure an airtight seal. It is important, when using this method, that the hose washer in the garden hose fitting is pliable and in good serviceable condition to ensure there is no air leak at this joint, which will cause the pump to not prime.

WARNING



Burn Hazard. Heated oil can cause burns. Wear protective gloves, clothing and safety glasses during the oil change process. Failure to do so may result in personal injury.

- The pump is reversible so it can pump oil in either direction. The switch (at rear of motor) has two "on" positions when it is moved to either side of center with the center position being the "off" position. To remove oil from the engine, move the switch in the direction of required flow. If using the 1/4" probe, watch for oil flowing through it. If oil does not appear in about 10 seconds, check the probe for possible sediment blockage and remove if present.

NOTICE: If the motor does not turn when first switched on, switch off the pump and loosen each of the end cover screws a couple of turns. Switch the pump on until the motor turns and then switch it off again. Retighten the end cover screws and start the oil removal process again.

- The motor will overspeed when the oil has been pumped out of the engine. Switch off the pump immediately to avoid impeller damage. Do not leave the pump unattended while pumping oil from the engine. Normal 6 quart pump-out takes less than 3 minutes.
- After all the oil has been removed from the engine, disconnect the alligator clips from the battery and carefully remove the dipstick probe from the dipstick tube.
- To empty the container with the pump when appropriate electrical power is nearby, remove 1/4" probe from the 48" hose and insert hose end in an approved receptacle. **Do not attempt to discharge oil through the 1/4" probe.** Connect the power cord to the proper power supply and switch on the pump by moving the switch toggle in the direction of desired flow. If proper electrical power is not available, pull up the retractable pour spout and carefully pour oil into a suitable receptacle.

NOTICE: Always recycle used oil in compliance with federal and local legislation. Handle petroleum products in an environmentally responsible manner.

EXPLODED VIEW

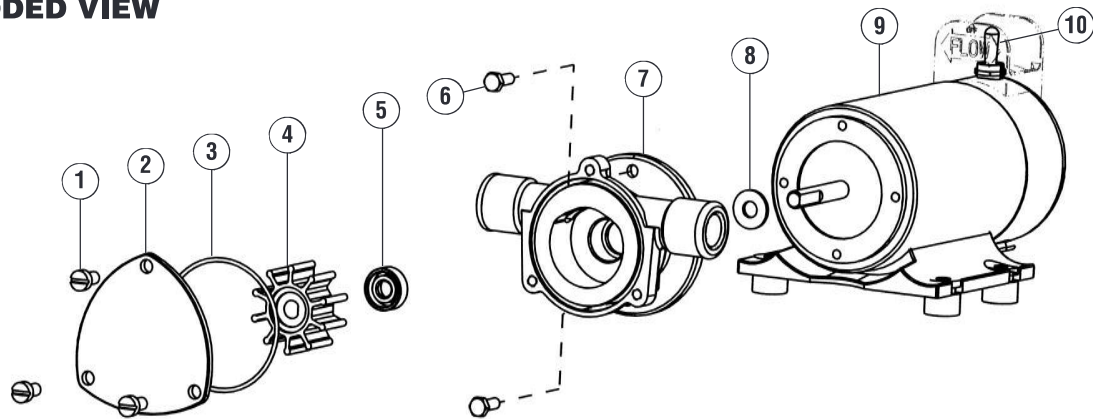

PARTS LIST

Key	Description	Part No.
1	Screw Kit (includes 3 screws)	91004-0090
2	End Cover	18647-0000
3	O-Ring*	18753-0660
4	Impeller*	9200-0023
5	Sea*	18753-0384
6	Screw Kit (includes 3 screws)	98019-0020

Key	Description	Part No.
7	Body	18646-0000
8	Slinger	6342-0000
9	Motor: 12 Volt, EMC	18753-0067
	24 Volt, EMC	18753-0636
10	Switch Polarity Reversing Service Kit	18753-0652 90061-0053

* Parts contained in Service Kit.

DISASSEMBLY

1. Remove end cover screws, end cover and O-ring.
2. Withdraw impeller.
3. Loosen and remove two slotted hex screws, which attach body to motor.
4. Tap body lightly between ports and remove body from motor.
5. With a 1/2" diameter dowel, push against the shaft seal from back (motor) side of the body to dislodge it from the seal bore.

NOTE: Do not tamper with or disassemble motor.

ASSEMBLY

1. Lubricate seal with water and position it in seal bore with lip, or hollowed-out side of seal, pointing towards the impeller bore. With a 1/2" diameter dowel, push against the shaft seal into its bore until it contacts the bottom.
2. Lubricate motor shaft and install body on motor.
3. Lubricate impeller bore and, aligning flat in impeller with flat on motor shaft, install impeller with clockwise rotary motion.
4. Install O-ring, end cover and screws.

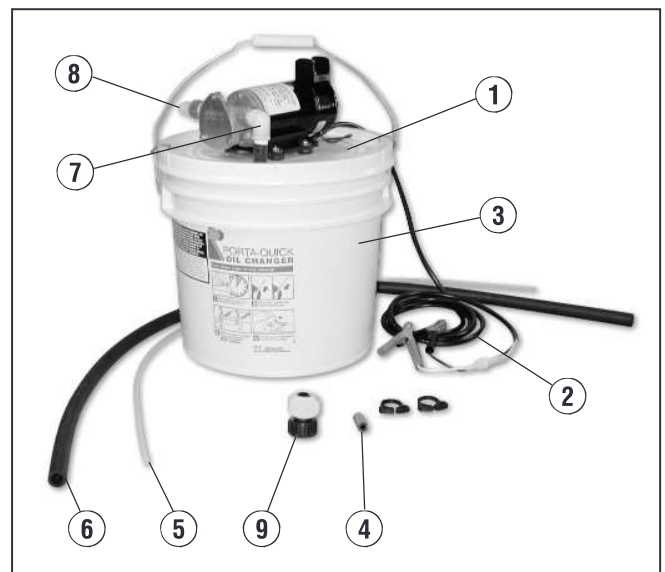

Key	Description	Qty.	Part Number
1	Lid	1	17794-0000
2	Power Cord	1	43922-0000
3	Pail	1	17089-0000
4	Hose Adaptor Sleeve	1	34423-1000
5	Dipstick Probe	1	18753-0608
6	Hose	1	17795-1000
7	Port Elbow & Tube	1	17834-1000
8	Port Adaptor Straight	1	93009-0190
9	1/2" Hose by Female Garden Hose Thread Fitting	1	†

† Available from Hardware Store.

ONE YEAR LIMITED WARRANTY

A. LIMITED WARRANTY:

Jabsco warrants that at the time of shipment, the products manufactured by Jabsco and sold hereunder shall be in conformity with applicable written specifications and descriptions referred to or set forth herein, free from defects in material and, merchantable, and suitable for a particular purpose, provided such is implied by State law under the circumstances of this sale.

B. WARRANTY ADJUSTMENT:

1. Jabsco agrees to repair or furnish a replacement for, but not to remove or install, any product or component thereof which, within one (1) year from date of purchase, shall upon test and examination by Jabsco prove defective within the above warranty. Receipt verifying purchase date is required to obtain adjustment.
2. Buyer shall notify Jabsco of any defect within this warranty no later than ninety (90) days after the defect is discovered.

C. EXCLUSIONS FROM WARRANTY AND LIMITATION OF LIABILITY:

1. The foregoing warranty is limited solely as set forth herein and applies only for the period designated above.
2. JABSCO SHALL NOT BE LIABLE FOR ANY LOSS, DAMAGE, SPECIAL OR CONSEQUENTIAL DAMAGE OF ANY KIND, WHETHER BASED UPON WARRANTY, CONTRACT, NEGLIGENCE, OR STRICT LIABILITY ARISING IN CONNECTION WITH THE SALE, USE, OR REPAIR OF THE PRODUCT.
3. THE MAXIMUM LIABILITY OF JABSCO IN CONNECTION WITH THIS WARRANTY SHALL NOT IN ANY CASE EXCEED THE CONTRACT PRICE FOR THE PRODUCT CLAIMED TO BE DEFECTIVE OR UNSUITABLE.

4. This warranty does not extend to any product manufactured by Jabsco which has been subjected to misuse, neglect, accident, improper installation, or use in violation of instructions furnished by Jabsco.
5. This warranty does not extend to or apply to any unit which has been repaired or altered at any place other than Jabsco's factory, or by persons not expressly approved by Jabsco, nor to any unit the serial number, model number, or identification of which has been removed, defaced or changed.
6. Components manufactured by any supplier other than Jabsco shall bear only that warranty made by the manufacturer of that product.
7. This warranty applies to products defined as "consumer products" by the Consumer Product Warranties Act as from time to time amended.

D. CONSUMER RIGHTS:

This warranty gives you specific legal rights, and you may have other rights which vary from state to state. Some states do not allow exclusion or limitation of damages.

STANDARD WARRANTY: If the products manufactured and sold hereunder are not Consumer Products, the warranty extended to Buyer shall be as set forth in subparagraphs (A), (B), and (C), **EXCEPT THAT ALL EXPRESS OR IMPLIED WARRANTIES OR MERCHANTABILITY OR SUITABILITY FOR ANY PARTICULAR PURPOSE ARE EXCLUDED.**

www.jabsco.com

THE PRODUCTS DESCRIBED HEREIN ARE SUBJECT TO THE JABSCO ONE YEAR LIMITED WARRANTY, WHICH IS AVAILABLE FOR YOUR INSPECTION UPON REQUEST.



For more information
visit us online at www.jabsco.com